

Classification

Electric submersible pump
 Protection class IP68
 Depth of submersion max. 30m
 Semi-vortex impeller with Agitator
 Max. solid handling 10mm
 Suitable for sludge, slurry, liquids containing mud

Electric Motor

Dry-type submersible induction motor,
 Insulation class E, 2 poles, 2850 r.p.m.
 Direct on line start
 Voltage: 400V, 50Hz, 3-phase
 Power input: 2,41kW
 Power output: 2,00kW
 Nominal current: 3,8A
 Start current: 30,0A

Electric Cable

20m HO7RN-F 4Cx1,5mm²

Motor Protection

Circle thermal protector
 (snap-action bi-metal device)

Shaft Seal

Double mechanical seal in oil bath
 additional lubrication by oil lifting device
 Primary Seal:
 silicon carbide on silicon carbide
 Secondary Seal:
 silicon carbide on silicon carbide

Bearings

Shielded ball bearings, maintenance-free

Materials

Impeller:	Chromium iron casting
Agitator:	FCD700 (EN-GJS-700-2)
Casing:	Synthetic rubber
Motor frame:	Aluminium alloy casting
Shaft:	SUS403 (EN-X6Cr13)

Discharge Connection

2" (50mm) hose coupling

Weight

24 kg (dry weight of the pump without cable)

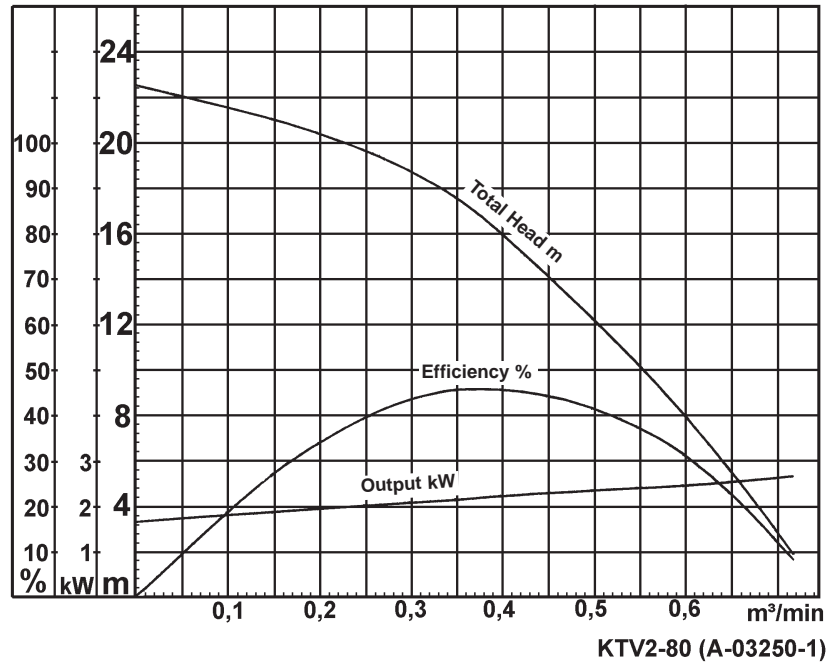
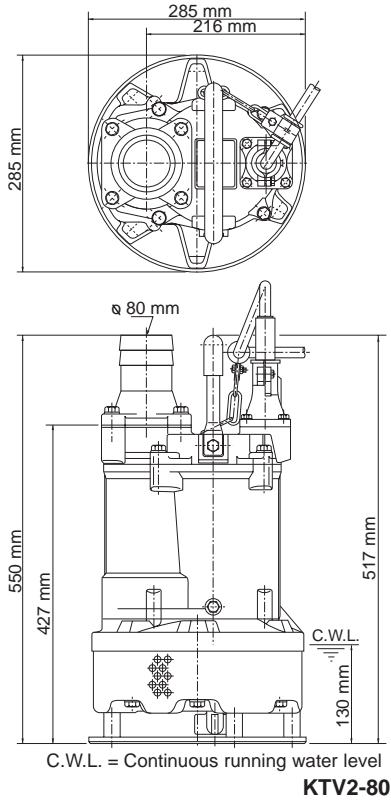

Classification

Electric submersible pump
Protection class IP68
Depth of submersion max. 30m
Semi-vortex impeller with Agitator
Max. solid handling 10mm
Suitable for sludge, slurry, liquids containing mud

Electric Motor

Dry-type submersible induction motor,
Insulation class E, 2 poles, 2850 r.p.m.
Direct on line start
Voltage: 400V, 50Hz, 3-phase
Power input: 3,9kW
Power output: 3,0kW
Nominal current: 6,1A
Start current: 48,0A

Electric Cable

20m HO7RN-F 4Cx1,5mm²

Motor Protection

Circle thermal protector
(snap-action bi-metal device)

Shaft Seal

Double mechanical seal in oil bath
additional lubrication by oil lifting device
Primary Seal:
silicon carbide on silicon carbide
Secondary Seal:
silicon carbide on silicon carbide

Bearings

Shielded ball bearings, maintenance-free

Materials

Impeller:	Chromium iron casting
Agitator:	FCD700 (EN-GJS-700-2)
Casing:	Synthetic rubber
Motor frame:	Aluminium alloy casting
Shaft:	SUS403 (EN-X6Cr13)

Discharge Connection

3" (80mm) hose coupling

Weight

37 kg (dry weight of the pump without cable)