

Movitec VCI – High-pressure Immersion Pump



Applications:

- Circulation of cooling lubricant in machine tools
- Recirculation in filter systems
- Condensate recirculation
- Industrial washing and cleaning processes
- Tank drainage

More information: www.ksb.com/products

Your contact:

POMP  IRECT

T 0294-457712 F 0294-457713 Info@Pompdirect.nl

Movitec VCI – High-pressure Immersion Pump

1 Maximum operating reliability

Top quality in pump engineering is based on advanced high-precision production technology and resistant high-grade materials. By adding to this quality a compact, easy-to-replace cartridge seal and automatic return of small amounts of leakage into the tank the new Movitec VCI offers top reliability.

2 Excellent efficiencies

Outstanding efficiencies are characteristic of Movitec VCI. Its optimum flow passage, high-efficiency motors and precision engineering of all hydraulic components make it an energy-saving, state-of-the-art pump solution.

3 Flexibility & diversity

The modular design of Movitec VCI brings many advantages: blind stages enabling flexible immersion depths, a large range of seal materials for the most diverse of applications, and a large number of motor options (e.g. with multiplug connector or special voltages). Interchanging competitor products with Movitec VCI is straightforward as they are of comparable dimensions.

4 Low life cycle costs

Energy costs make up approximately 80 % of a pump's total life cycle costs. This is only one aspect of Movitec VCI's competitive edge. It also clearly beats the competition in initial investment as well as maintenance costs.

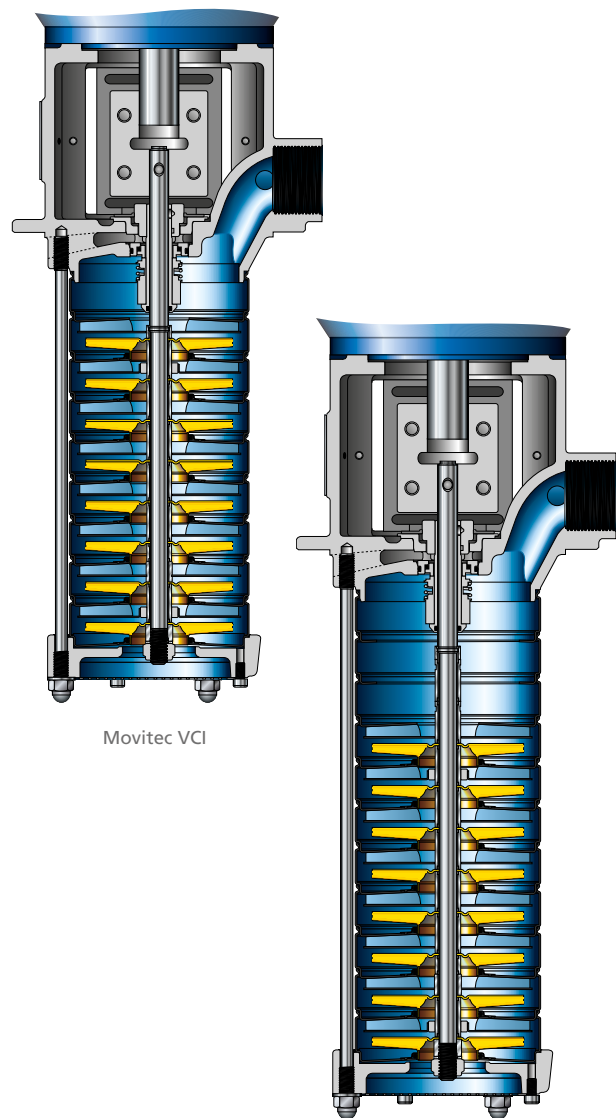

Movitec VCI

Movitec VCI with blind stages

Technical data*

Sizes	2 / 4 / 6	10 / 15
Flow rate	up to 9 m ³ /h	up to 22 m ³ /h
Head	up to 250 m	up to 245 m
Discharge-side mating dimension	Pipe connection G 5/4 internal thread	Pipe connection G2 internal thread
Maximum immersion depth	840 mm	555 mm
Pressure class	PN25	PN25
Fluid temperature	-10 to +90 °C	-10 to +90 °C
* (50 Hz)		

Materials

Sizes	2 / 4 / 6 / 10 / 15
Hydraulic system	Stainless steel 1.4301
Motor stool and suction casing	Grey cast iron JL1040, with cataphoretic coating