

Toyo

Wear resistant pumps with agitator

**TECHNICAL SPECIFICATIONS
DPH PUMPS**

Performance curves

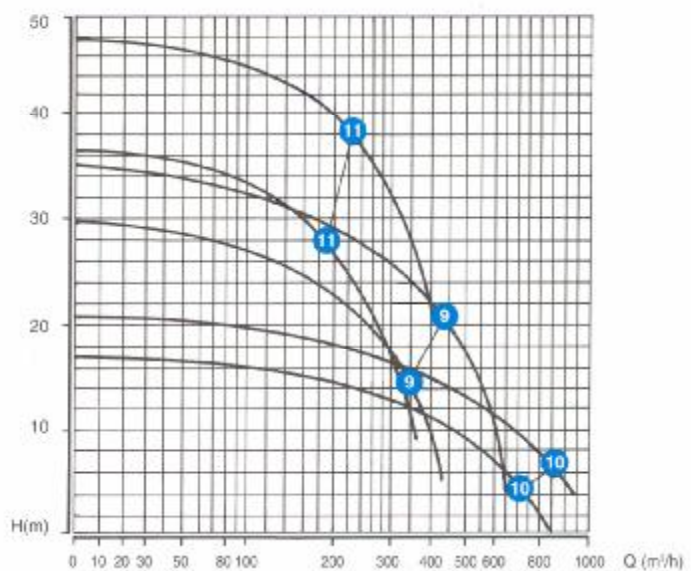
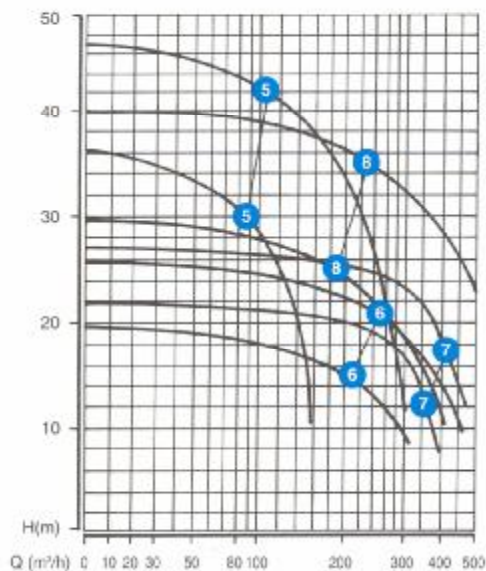
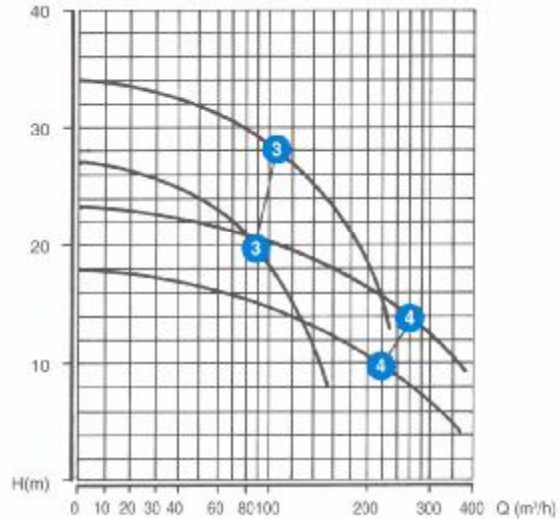
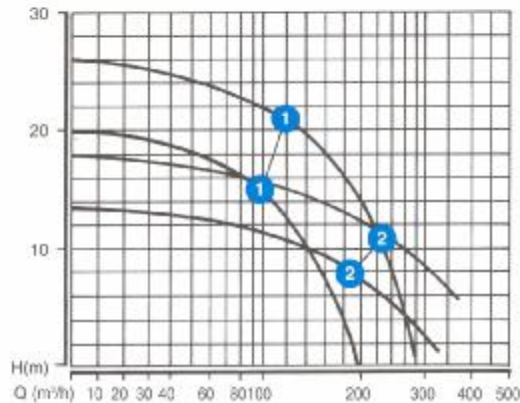

Nr	Type	Outlet (inch)(mm)		Capacity (m ³ /h)		Manom. head (m)		Particle size (mm)	Power (kW)		Revolution (1/min)		Weight (kg)
				min	max	min	max		min	max	min	max	
1	DPH 15	4	100	90	120	15	21	35	11	18.5	960	1150	360
2	DPH 15B	6	150	190	228	8	11	60	11	18.5	960	1150	380
3	DPH 20	4	100	90	108	20	28	35	16	25.5	960	1150	385
4	DPH 20B	6	150	220	264	10	14	60	16	25.5	960	1150	405
5	DPH 30	4	100	90	108	30	42	35	26	38	960	1150	590
6	DPH 30B	6	150	210	252	15	21	60	26	38	960	1150	570
7	DPH 40B	8	200	360	432	12	17	40	32	47	960	1150	580
8	DPH 50	6	150	190	228	25	35	60	40	59	960	1150	660
9	DPH 50B	8	200	360	432	15	21	60	40	59	960	1150	680
10	DPH 50BL	10	250	720	864	5	7	100	40	59	960	1150	930
11	DPH 50H	6	150	190	223	28	38	40	40	59	960	1150	950
12	DPH 100B	8	200	360	428	30	42	60	86	129	740	880	1800
13	DPH 100BL	10	250	720	856	15	21	100	86	129	740	880	2200
14	DPH 300	8	200	390	487	40	62	120	124	220	590	750	2900
15	DPH 300L	8	200	480	600	30	46	120	124	220	590	750	2900
16	DPH 300B	10	250	720	900	22	34	120	124	220	590	750	2940

Performance curves

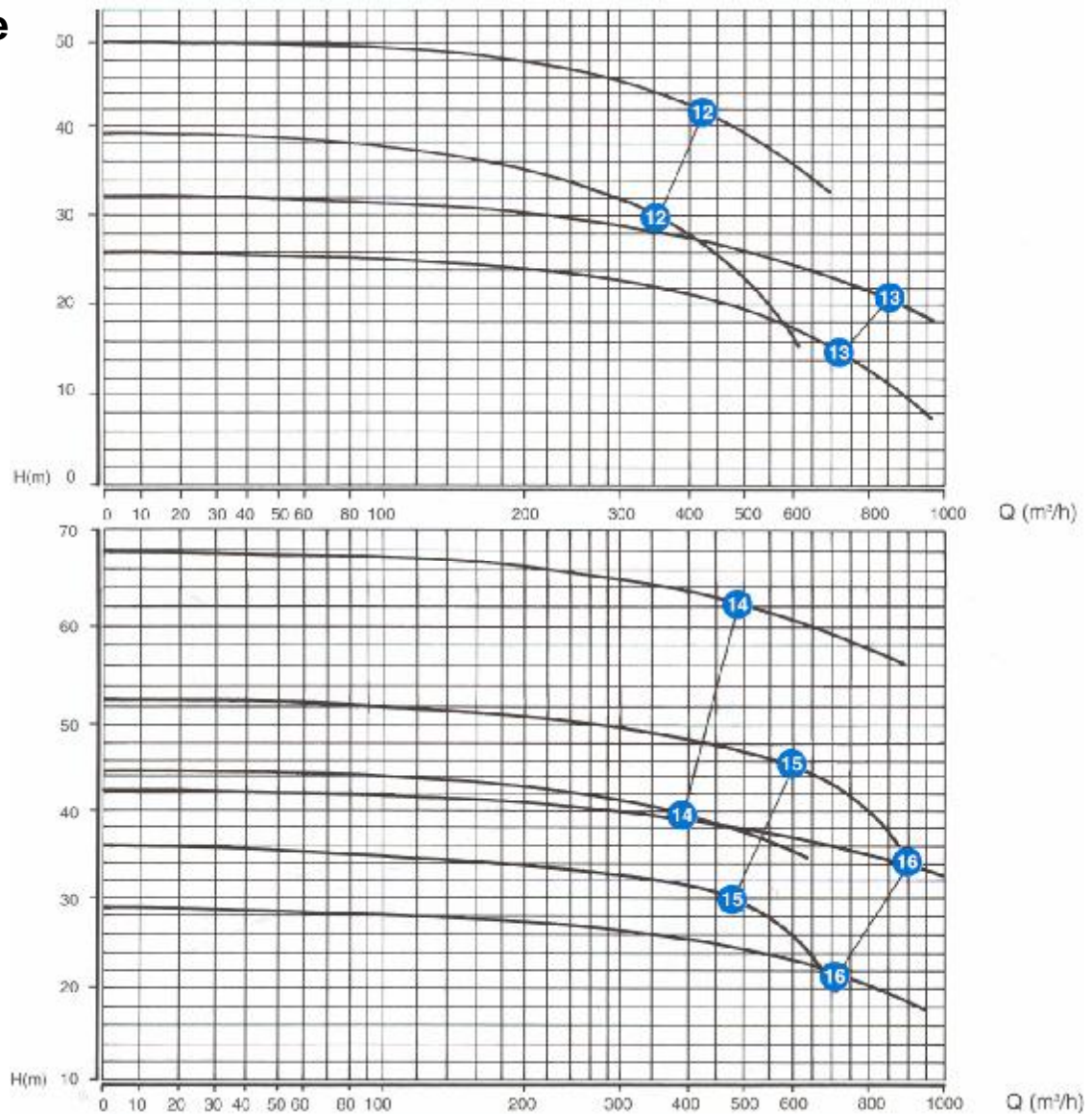

Nr	Type	Hydr. motor Type	Revolution (1/min)		Flow motor (l/min)		Motor capacity CC	Motor press. (bar)		Fittings SAE		
			min	max	min	max		min	max	inlet	outlet	drain
1	DPH 15	Volvo F12.40	960	1150	39	45	40	180	250	3/4"	3/4"	3/4"-16
2	DPH 15B	Volvo F12.40	960	1150	39	45	40	180	250	3/4"	3/4"	3/4"-16
3	DPH 20	Volvo F12.60	960	1150	58	67	59.8	180	250	3/4"	3/4"	7/8"-14
4	DPH 20B	Volvo F12.60	960	1150	58	67	59.8	180	250	3/4"	3/4"	7/8"-14
5	DPH 30	Volvo F12.80	960	1150	78	90	80.4	180	250	1"	1"	7/8"-14
6	DPH 30B	Volvo F12.80	960	1150	78	90	80.4	180	250	1"	1"	7/8"-14
7	DPH 40B	Volvo F12.110	960	1150	110	127	110.1	210	250	1 1/4"	1 1/4"	3/4" BSP
8	DPH 50	Volvo F12.110	960	1150	110	127	110.1	210	250	1 1/4"	1 1/4"	3/4" BSP
9	DPH 50B	Volvo F12.110	960	1150	110	127	110.1	210	250	1 1/4"	1 1/4"	3/4" BSP
10	DPH 50BL	Volvo F12.110	960	1150	110	127	110.1	210	250	1 1/4"	1 1/4"	3/4" BSP
11	DPH 50H	Volvo F12.110	960	1150	110	127	110.1	210	250	1 1/4"	1 1/4"	M33x2
12	DPH 100B	Rexroth A2FM M355	740	880	275	320	355	210	300	1 1/2"	1 1/2"	M33x2
13	DPH 100BL	Rexroth A2FM M355	740	880	275	320	355	210	300	1 1/2"	1 1/2"	M33x2
14	DPH 300	Rexroth A2FM M500	590	750	308	386	500	177	300	1 1/2"	1 1/2"	M33x2
15	DPH 300L	Rexroth A2FM M500	590	750	308	386	500	177	300	1 1/2"	1 1/2"	M33x2
16	DPH 300B	Rexroth A2FM M500	590	750	308	386	500	177	300	1 1/2"	1 1/2"	M33x2

DIMENSIONS AND OTHER TECHNICAL INFORMATION **Toyo**

DIMENSIONS	A	B	C	D	E	F	G	H	I	J
1 DPH 15	1087	500	350	260	280	197	300	445	500	750
2 DPH 15B	1087	560	330	280	280	197	300	445	560	841
3 DPH 20	1104	495	345	265	280	214	300	515	495	825
4 DPH 20B	1104	560	330	280	280	214	300	445	560	841
5 DPH 30	1165	515	365	280	280	240	360	635	515	910
6 DPH 30B	1165	580	350	295	280	240	360	510	580	955
7 DPH 40B	1189	580	350	295	280	264	360	510	600	1010
8 DPH 50	1274	635	405	325	280	264	360	560	635	1020
9 DPH 50B	1274	635	405	325	280	264	360	560	655	1065
10 DPH 50BL	1349	760	462.5	342.5	280	264	360	560	762.5	1350
11 DPH 50H	1279	650	420	315	280	264	360	660	650	1094
12 DPH 100B	1810	695	445	415	600	350	520	760	695	1570
13 DPH 100BL	1993	840	540.5	502.5	600	350	520	820	840.5	1645
14 DPH 300	2270	940	640	634	600	396	520	1010	940	1610
15 DPH 300L	2330	970	640	634	600	396	520	1010	940	1610
16 DPH 300B	2330	970	670	664	600	396	520	1010	970	1695

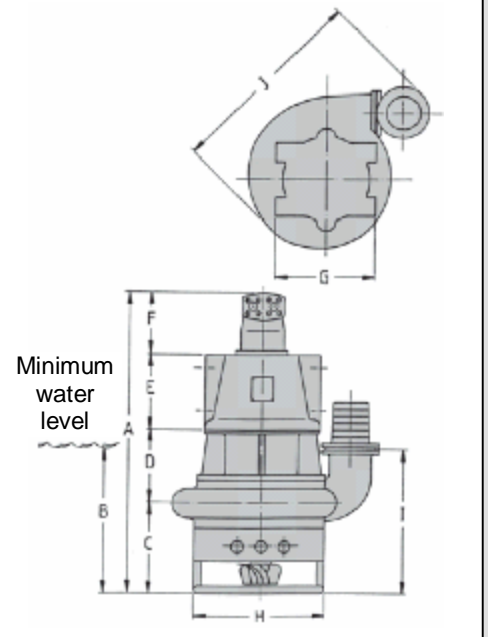

• Concept :

The TOYO DPH range of submersible pumps with agitator has been specially designed to handle heavy and abrasive slurries.

These centrifugal pumps with closed impeller feature a unique agitator design. This agitator lifts sediments into suspension, creating a slurry mixture. This enables the continuous pumping of media with a high concentration of solids.

Robust construction, careful selection of materials and unique contour components, coupled with a low speed high torque motor, have produced a pump with excellent abrasion resistance capable of handling the toughest of applications. These characteristics ensure long service life and economical operation.

The impeller, the wear plates and the agitator are manufactured in cast chrome iron (24 to 28 % Cr).

A strong short shaft, supported by a series of carefully selected bearings and an assembly of special lip seals, operating in an oil bath, ensure tightness in the hardest of conditions.

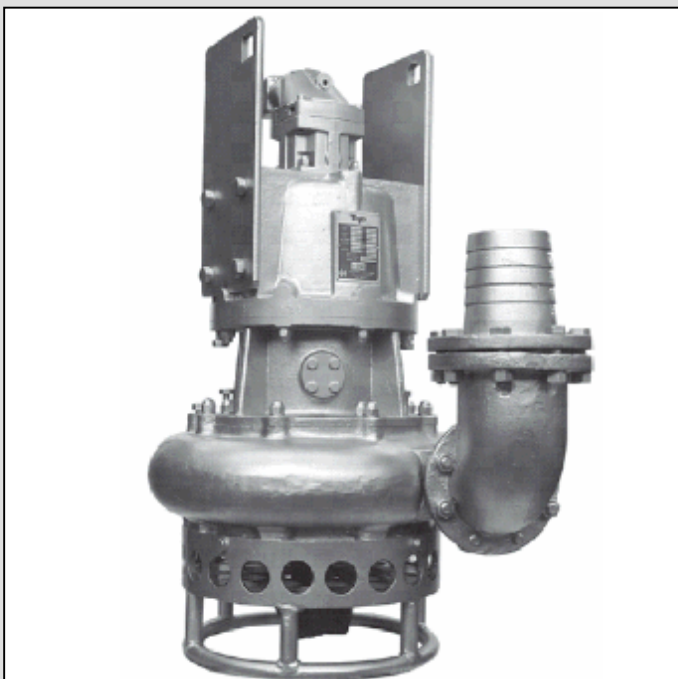

Servicing and maintaining the pumps to keep them in good working order is easy. On the DPH pumps you have two wear plates, one of which is adjustable allowing simple adjustments to maintain long lasting high performance.

A powerful hydraulic piston motor driving the DPH pumps offer the following specific characteristics :

- The speed of rotation is adjustable, which enables the pumps capacity and pressure to be adapted to suit site requirements and circumstances
- The concentration of solids in the pumped liquid can be up to 70% by weight with a maximum density of 1.4 kg/dm³

In applications where the pump is mounted onto the arm of an excavator, it can be directly connected to the excavator's hydraulic system.

As the oil from the hydraulic power pack cools the motor it allows the DPH pump to operate partially submerged. The pump cans also be used in explosive environments. These pumps are available with biodegradable oil, in different metallurgies as well as in special versions for high depths.

• Operating conditions :

DPH pumps can handle slurries with solid content of up to 70 % by weight, particle sizes up to 120 mm and liquid temperatures up to 60°C with pH levels between 4 and 9.5. Its standard operating depth is 30 m and maximum 120 m in special versions.

TOYO PUMPS EUROPE

Parc Industriel Sud - Zone II
Rue de l'Industrie 41 - BE - 1400 Nivelles - Belgium
Tel. : +32(0)67 64 55 37 - Fax : +32(0)67 64 55 31
E-mail : sales@toyopumpseurope.com
Website : www.toyopumpseurope.com

POMP  IRECT

Tel 0294-457712 info@pompdirect.nl