

# Toyo

**Wear resistant pumps with agitator**

---

**TECHNICAL SPECIFICATIONS  
DP 3~10CV PUMPS**

---

## Performance curves

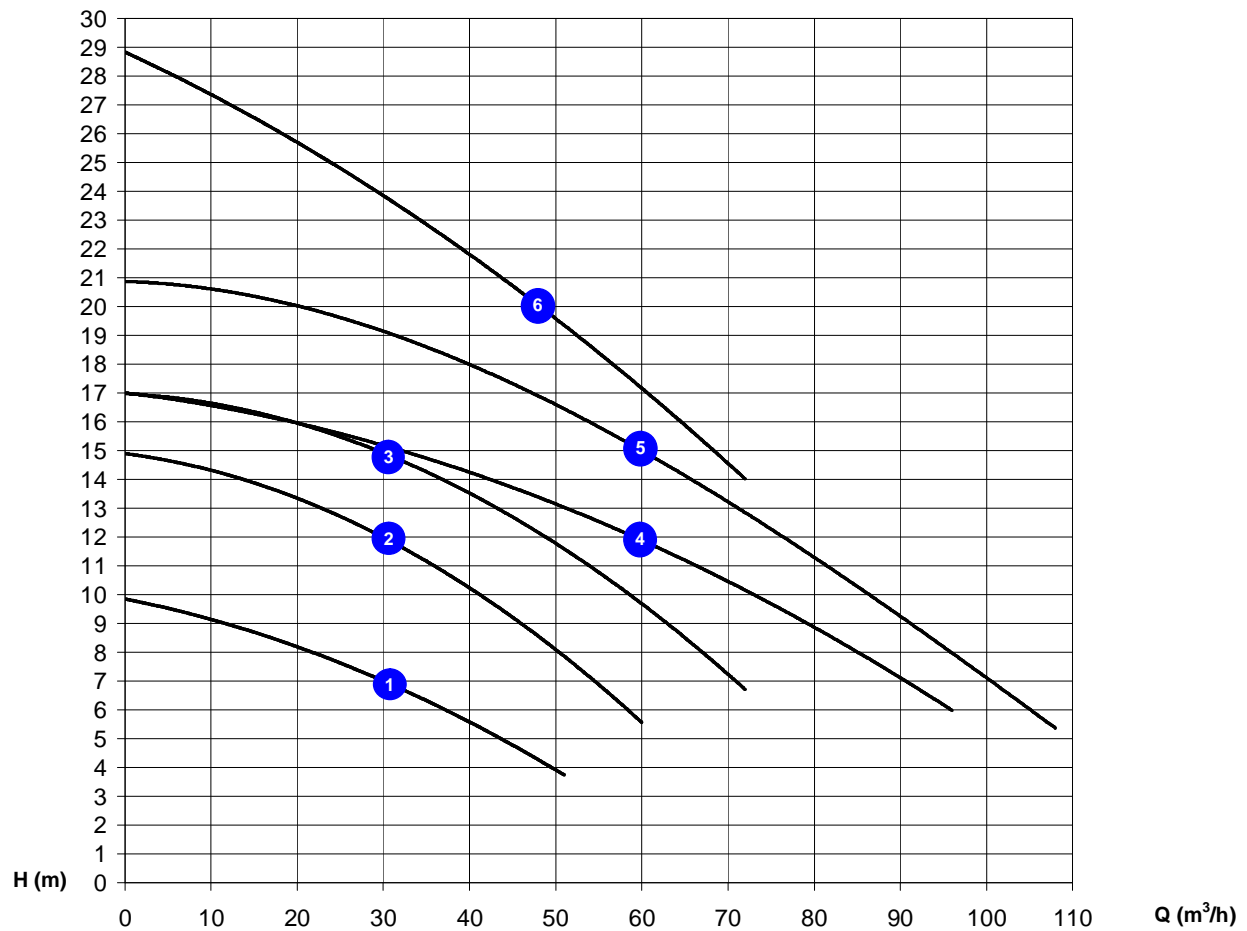

Nr	Type	Outlet (inch)	Outlet (mm)	Capacity (m³/h)	Manom. head (m)	Particle Size (mm)	Power (kW)	Revolution (1/min) 50Hz	Current (A) 400 V	Electr. Cable	Weight (kg)
1	DP 3	3	80	30	7	20	2.2	1430	5.0	4x6mm <sup>2</sup>	145
2	DP 5	3	80	30	12	20	3.7	1430	8.3	4x6mm <sup>2</sup>	165
3	DP 7.5	3	80	30	15	25	5.5	1445	11.8	4x10mm <sup>2</sup>	195
4	DP 7.5B	4	100	60	12	25	5.5	1445	11.8	4x10mm <sup>2</sup>	195
5	DP 10	4	100	60	15	25	7.5	1445	16.3	4x10mm <sup>2</sup>	215
6	DP 10H	4	100	48	20	14	7.5	1445	16.3	4x10mm <sup>2</sup>	225

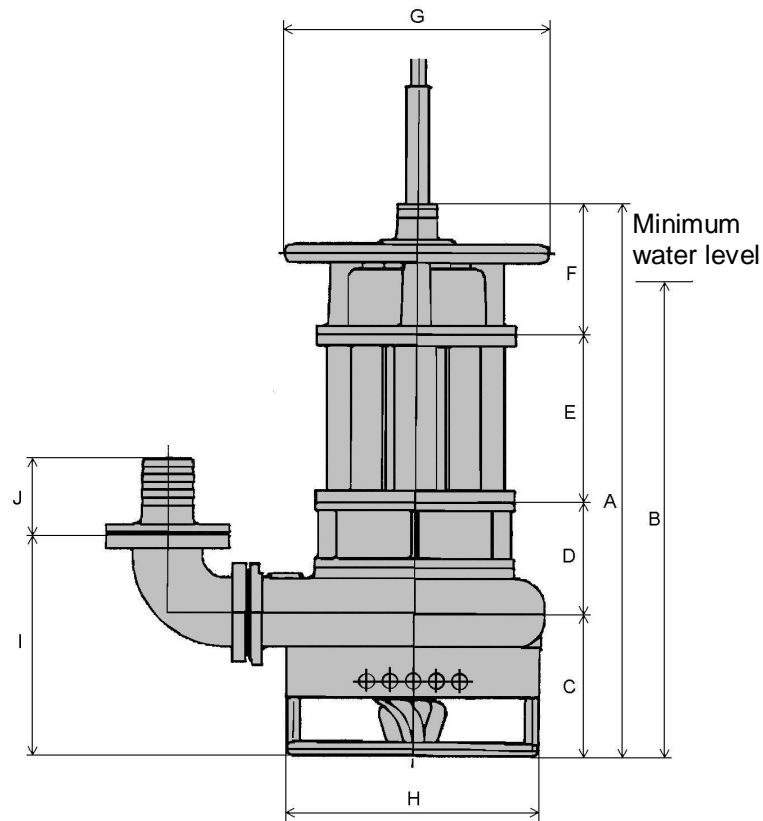
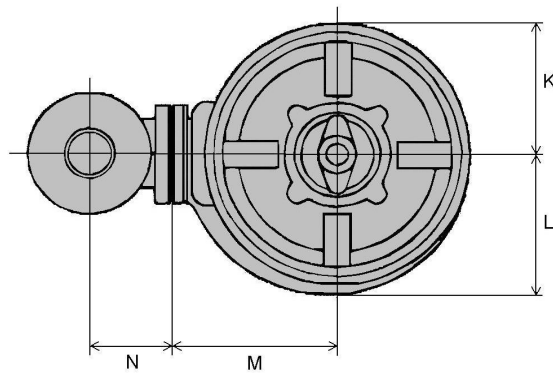

DIMENSIONS		A	B	C	D	E	F	G	H	I	J	K	L	M	N
1	DP 3	785	680	200	160	235	190	360	320	320	115	180	190	240	123
2	DP 5	840	700	200	160	290	190	360	320	320	115	180	190	240	123
3	DP 7.5	850	700	220	170	260	200	400	380	340	115	200	215	250	123
4	DP 7.5B	850	700	225	165	260	200	400	380	385	143	200	225	250	163
5	DP 10	890	740	225	165	300	200	400	380	385	143	200	225	250	163
6	DP 10H	890	740	225	165	300	200	400	440	385	143	230	255	280	163

• **Concept :**

The TOYO DP range of submersible pumps with agitator has been specially designed to handle heavy and abrasive slurries.

These centrifugal pumps with semi-open impeller feature a unique agitator design. This agitator lifts sediments into suspension, creating a slurry mixture. This enables the continuous pumping of media with a high concentration of solids.

Robust construction, careful selection of materials and unique contour components, coupled with a low speed high torque motor, have produced a pump with excellent abrasion resistance as well as a sufficient weight and an important torque. These characteristics ensure long service life and economical operation.

The impeller, the wear plate and the agitator are manufactured in cast chrome iron (24 to 28 % Cr).

A strong short shaft supported by a series of carefully selected bearings and a double mechanical, operating in an oil bath, ensure tightness in the hardest of conditions.

Servicing and maintaining the pumps to keep them in good working order is easy. The adjustable wear plate allows simple adjustments to maintain long lasting high performance.

The electric class F motor is cooled by the liquid in which the pump is submerged.

The DP3~10HP pumps are equipped with a thermal protection in standard version. They are available in different metallurgies as well as in special versions for high temperatures.

• **Operating conditions :**

DP3~10HP pumps can handle slurries with solid content of up to 50 % by weight, particle sizes up to 25 mm and liquid temperatures up to 60°C with pH levels between 4 and 9,5. Special versions are available for liquid temperatures up to 80°C. Maximal operating depth is 30 m.

• **Electric power requirements\* :**

Pump type	Power kVA	Amp. 400 V
DP 3	6	5.0
DP 5	12	8.3
DP 7.5/B	15	11.8
DP 10/H	20	16.3

\*These figures are given as an indication.

• **Electric cable :**

The standard cable type to be used for connecting the pump is HO7RN-F and its specifications should correspond to the following :

Pump type	Section	Outer. diam. mm	Max. length m / 400V
DP 3	4 x 6 mm <sup>2</sup>	19	500
DP 5	4 x 6 mm <sup>2</sup>	19	350
DP 7.5/B	4 x 10 mm <sup>2</sup>	23	350
DP 10/H	4 x 10 mm <sup>2</sup>	23	250



## TOYO PUMPS EUROPE

Parc Industriel Sud - Zone II  
 Rue de l'Industrie 41 - BE - 1400 Nivelles - Belgium  
 Tel. : +32(0)67 64 55 37 - Fax : +32(0)67 64 55 31  
 E-mail : [sales@toyopumpseurope.com](mailto:sales@toyopumpseurope.com)  
 Website : [www.toyopumpseurope.com](http://www.toyopumpseurope.com)



Tel 0294-457712 [info@pompdirect.nl](mailto:info@pompdirect.nl)