

Toyo

Wear resistant pumps with agitator

**TECHNICAL SPECIFICATIONS
ET PUMPS**

Performance curves

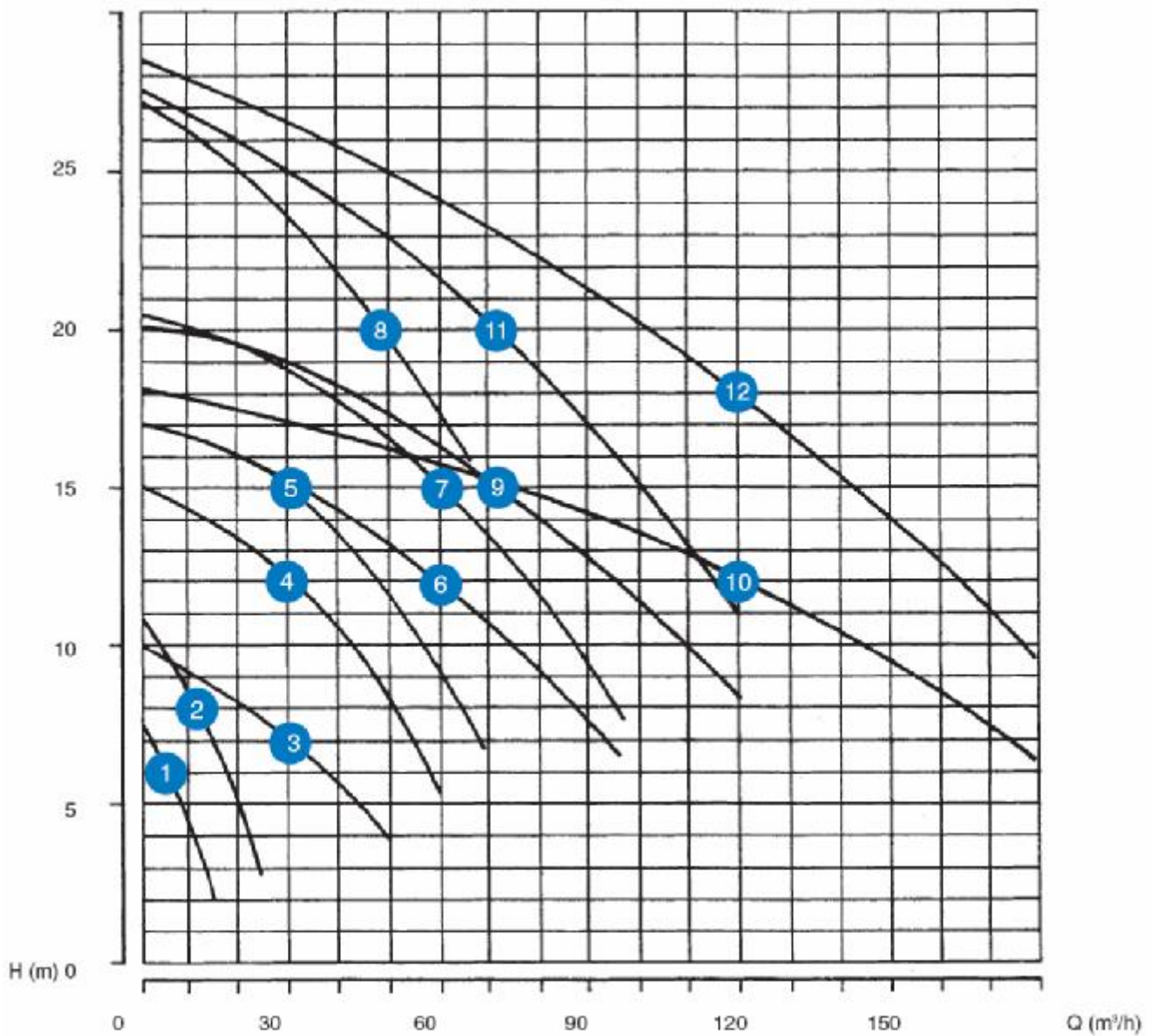

Nr	Type	Outlet (inch)(mm)	Capacity (m ³ /h)	Manom. head (m)	Particle size (mm)	Power (kW)	Revolution (1/min) 50Hz	Current (A) 400V	Electr. cable	Weight (kg)
1	ET 1	2 50	6	6	10	0.75	1415	2.2	4x6mm ²	90
2	ET 2	2 50	12	8	10	1.5	1430	3.5	4x6mm ²	95
3	ET 3	3 80	30	7	20	2.2	1430	5.0	4x6mm ²	145
4	ET 5	3 80	30	12	20	3.7	1430	8.3	4x6mm ²	165
5	ET 7.5	3 80	30	15	25	5.5	1445	11.8	4x10mm ²	195
6	ET 7.5B	4 100	60	12	25	5.5	1445	11.8	4x10mm ²	195
7	ET 10	4 100	60	15	25	7.5	1445	16.3	4x10mm ²	215
8	ET 10H	4 100	48	20	14	7.5	1445	16.3	4x10mm ²	225
9	ET 15	4 100	72	15	30	11	1420	23.0	4x10mm ²	300
10	ET 15B	6 150	120	12	30	11	1420	23.0	4x10mm ²	300
11	ET 20	4 100	72	20	30	15	1445	31.0	4x10mm ²	320
12	ET 20B	6 150	120	18	30	15	1420	31.0	4x10mm ²	320

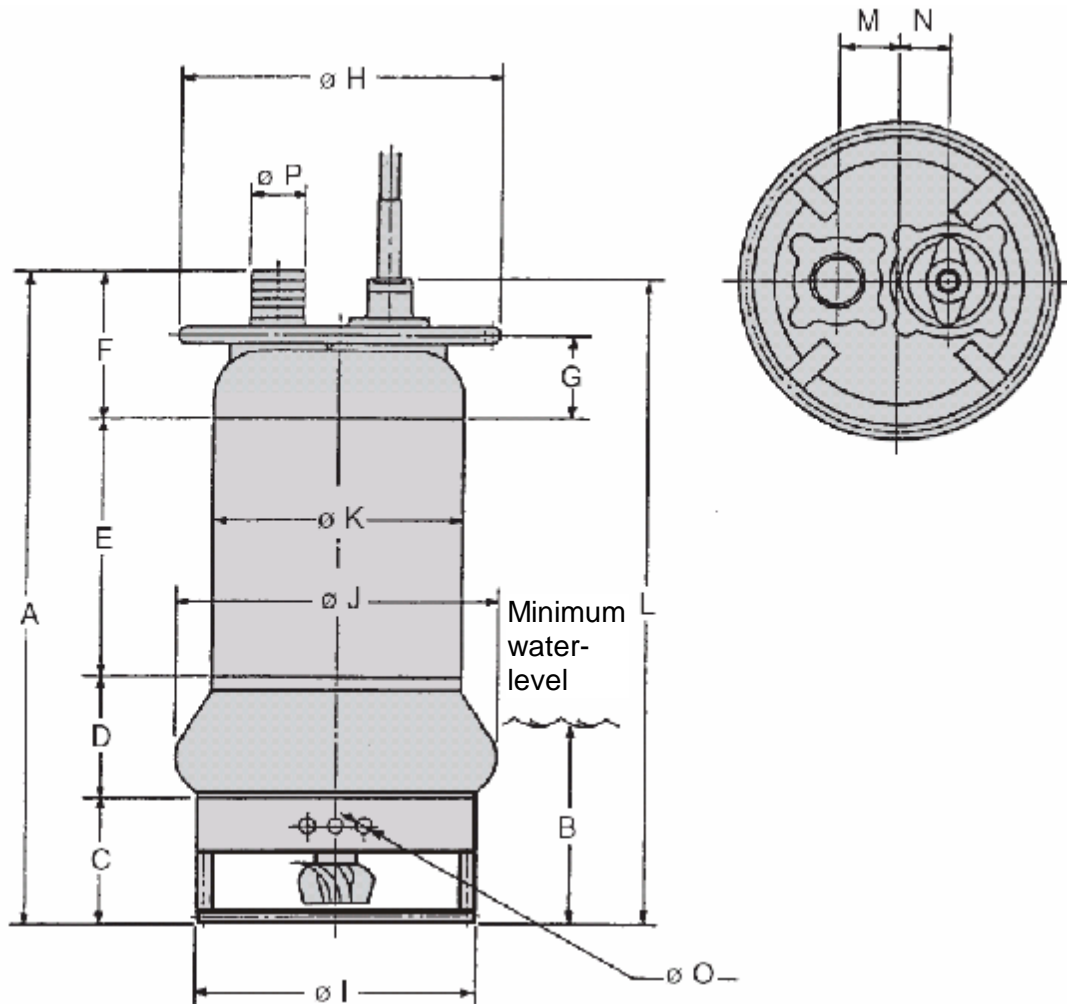

DIMENSIONS	A	B	C	D	E	F	G	H	I	J	K	L	M	N	O	P
1 ET 1	658	190	120	130	230	178	106	310	280	310	255	660	75	40	10	50
2 ET 2	688	190	120	130	260	178	106	310	280	310	255	690	75	40	10	50
3 ET 3	798	245	145	170	280	203	111	360	320	360	300	785	80	55	20	80
4 ET 5	853	245	145	170	335	203	111	360	320	360	300	840	80	55	20	80
5 ET 7.5	863	265	165	170	320	208	119	440	380	440	340	850	85	70	25	80
6 ET 7.5B	883	265	165	170	320	228	119	440	380	440	340	850	85	70	25	100
7 ET 10	923	265	165	170	360	228	119	440	380	440	340	890	85	70	25	100
8 ET 10H	923	265	165	170	360	228	119	440	440	450	340	890	85	70	14	100
9 ET 15	1033	350	215	225	345	248	129	500	420	500	410	1020	100	100	30	100
10 ET 15B	1063	350	215	225	345	278	129	500	420	500	410	1020	100	100	30	150
11 ET 20	1078	350	215	225	390	248	129	500	420	500	410	1065	100	100	30	100
12 ET 20B	1108	350	215	225	390	278	129	500	420	500	410	1065	100	100	30	150

• **Concept :**

The TOYO ET range of submersible pumps with agitator has been specially designed to handle heavy and abrasive slurries.

These centrifugal pumps with semi-open impeller feature a unique agitator design. This agitator lifts sediments into suspension, creating a slurry mixture. This enables continuous pumping of media with a high concentration of solids.

Robust construction, careful selection of materials and unique contour components have produced a pump with excellent abrasion resistance. These characteristics ensure long service life and economical operation. The impeller, the wear plates and the agitator are manufactured in cast chrome iron (24 to 28 % Cr).

A strong short shaft, supported by a series of carefully selected bearings, and a double mechanical seal, operating in an oil bath, ensure tightness in the hardest of conditions.

The axial flow of the pumped liquid secures the cooling of the class F motor and makes partial immersing possible. This design reduces the outer dimensions of pump and hoses assembly.

Servicing the pumps and maintaining good working order is easy. One adjustable wear plate allows simple adjustments to maintain long lasting high performance.

The standard ET pumps are equipped with a thermal protection. They are available in special versions for high temperatures.

• **Operating conditions :**

ET pumps can handle slurries with solid content of up to 50 % by weight, particle sizes up to 30 mm and liquid temperatures up to 60°C with pH levels between 4 and 9,5. Special versions are available for liquid temperatures up to 80°C. The maximum operating depth is 30 m.



• **Electric power requirements * :**

Pump type	Power kVA	Amp. 400 V
ET 1	3	2.2
ET 2	5	3.5
ET 3	6	5.0
ET 5	12	8.3
ET 7.5/B	15	11.8
ET 10/H	20	16.3
ET 15/B	30	23.0
ET 20/B	40	31.0

* These figures are given as an indication

• **Electric cable :**

The standard cable type to be used for connecting the pump is HO7RN-F and its specifications should correspond to the following :

Pump type	Section	Outer diam. mm	Max. length m / 400V
ET 1	4 x 6 mm ²	19	700
ET 2	4 x 6 mm ²	19	600
ET 3	4 x 6 mm ²	19	500
ET 5	4 x 6 mm ²	19	350
ET 7.5/B	4 x 10 mm ²	23	350
ET 10/H	4 x 10 mm ²	23	250
ET 15/B	4 x 10 mm ²	23	180
ET 20/B	4 x 10 mm ²	23	120

• **Starter :**

A reactor starter has to be used from ET15/B on.

TOYO PUMPS EUROPE

Parc Industriel Sud - Zone II
 Rue de l'Industrie 41 - BE - 1400 Nivelles - Belgium
 Tel. : +32(0)67 64 55 37 - Fax : +32(0)67 64 55 31
 E-mail : sales@toyopumpseurope.com
 Website : www.toyopumpseurope.com



Tel 0294-457712 info@pompdirect.nl