

TABLE OF CONTENTS

Part III

- 3.0 Type code explanation
- 3.1 Service connections
- 3.2 Impeller clearance adjustment for wear
 - 3.2.1 Impeller clearance adjustment
- 3.3 Disassembly of hydraulic parts
 - 3.3.1 Disassembly for inspection
 - 3.3.2 Removal of impeller
 - 3.3.3 Removal of suction cover and wear rings
- 3.4 Assembly of impeller
- 3.5 Final assembly

Dat: 06.12.96

No: 94-BA 5073E/ 2

File: Q_HYDF_E

3.0 TYPE CODE EXPLANATION

The type code is found on the first line of the pump name plate.

Example:

H06F-M05
 ───────────
 |
 hydraulic code

HYDRAULIC CODE:

H 0 6 F - M 0 5 S

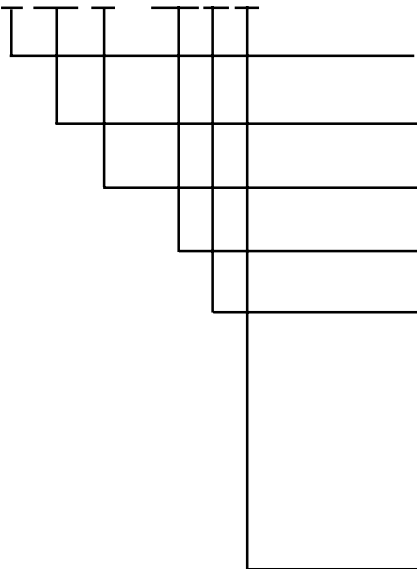

hydraulic size (X,B,C,D,E,F,H,etc.)

discharge flange size (in inches)

impeller type (F)

impeller size

material:

1 = standard pump: all castings of grey iron (GG20), except impeller of nodular iron (GGG 60).

5 = corrosion resistance: all wetted parts of stainless steel.

S = special execution

3.1 SERVICE CONNECTIONS

On Volute

These comprise of a gauge connection (424) on the discharge flange.

When the pump is mounted horizontally with the discharge flange vertical, and drain plug (423) is provided at the lowest part of the volute casing.

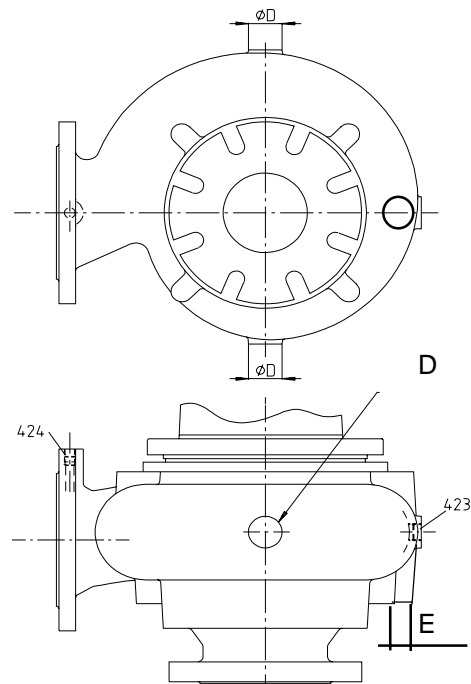

Fig. 1

Pos. Type	423	424	D mm	E mm
X01F	R 1/8"	R 1/8"	-	-
B02F	R 1/2"	R 1/4"	-	-
C03F	R 1/2"	R 1/4"	-	-
D03F	R 1/2"	R 1/4"	40	-
D04F	R 1/2"	R 1/4"	35	-
E04F	-	R 1/2"	-	60
F05F	-	R 1/2"	-	60
H06F	-	R 1/2"	-	60
I 08F	-	R 1/2"	-	60
L12F	R 1"	R 1/2"	60	-

Dat: 30.06.03

No: 94-BA 5073E/ 3b

File: Q_HYDF_E



3.2 IMPELLER CLEARANCE ADJUSTMENT FOR WEAR

The impeller gap should be checked and readjusted whenever a significant decrease in pump performance is noticed, or at least once every year (until experience indicates how often this will be required).

Excessive clearance can cause a drop in performance. Less clearance than the minimum listed can overload the motor and/or cause vibration due to a too great friction.

The clearance can be adjusted by changing the thickness of the shims (411) between the drive unit and the volute casing (400).



3.2.1 IMPELLER CLEARANCE ADJUSTMENT

For final assembly: Place the hydraulic (already built together) with the suction flange on a flat and hard underground. Lower the drive unit - impeller assembly into casing (400) by a suitable hoist.

For wear adjustment: Loosen all fasteners (419) between drive unit and volute casing. Remove shims.

General: To **estimate correct shim (411) thickness**, lower drive unit into casing just until impeller cannot be turned. Measure gap between drive unit and volute casing at several places and take average. Now add 0.5 mm to the average gap measured; this will be approximate shim thickness required to obtain correct clearance "C" (Fig. 3).

NOTE: If impeller tip is binding, see section 3.5.

If necessary, loosen fasteners (419) again, lift drive unit as much as required to place shims of calculated thickness between drive unit and volute casing. Use washers of **uniform thickness**, or U-shaped shimstock. These must be placed under **each** fastener (419). Thin shims may be a single piece of steel wire (diameter = calculated thickness) wrapped all the way around drive unit, under the studs (419); ends can be bent outward around last studs (419), to avoid overlapping.

Tighten fasteners (419) again, and with a feeler gauge, check the actual clearance between impeller and wear ring (reaching in through the suction of the pump). If the clearance "C" is significantly different to the table (Fig. 2), it is possible that the wear is excessive or not uniform: disassembly and inspection is recommended.

If this adjustment procedure does not restore original pump performance, or if excessive damage of handled materials is noted, examine wear on impeller or casing, replace worn parts as necessary.

Pump size	Impeller clearance	
	"C" mm	"B" mm
X	0.5 - 1.0	0.2 - 1.0
F-L	1.0 - 2.0	0.2 - 2.0

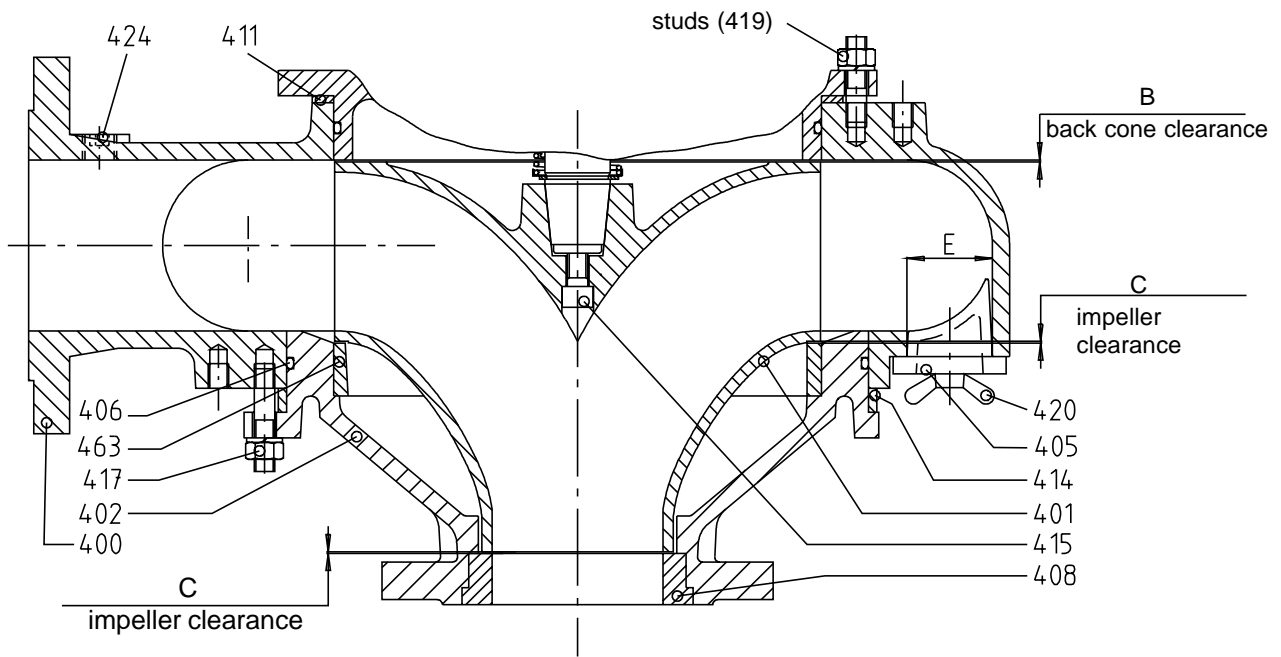

Fig. 2

3.3 DISASSEMBLY OF HYDRAULIC PARTS

3.3.1 DISASSEMBLY FOR INSPECTION

Casing should be placed with the suction flange on the workbench, and the drive unit-impeller assembly removed or lowered into place from above by a suitable hoist.

Remove nuts (419) around the flange. Lift the rotating assembly including impeller from the pump casing. Areas to be examined for wear will be the impeller surface and the machined surface on the wear rings. Uniform wear on any of these surfaces can be compensated by re-shimming or adjusting according to Section 3.2. However, excessive or uneven wear will require replacement of the worn parts.

3.3.2 REMOVAL OF IMPELLER

Hold the impeller (401) from turning by hand, or by a strap wrench, or by locking pliers clamped to the impeller. Inset a hexagonal key wrench into the impeller bolt (415) and with a hammer, tap the wrench counterclockwise to loosen the bolt.

FACTORY FITTED IMPELLER BOLTS		
SIZE	HEXAGON	TORQUE Nm
M8	6	17.5
M10	8	35.5
M12	10	61.5
M16	14	147.0
M20	17	285.0
M27	19	380.0
M33	24	700.0
M42	32	1100.0
M56	41	1700.0

3.3.3 REMOVAL SUCTION COVER AND WEAR RINGS (Fig. 2)

Some pumps have a one-piece suction cover (402) which is bolted to the volute casing (400) by studs and nuts (417). Adjustment of clearance is by shims (411) between the volute casing and the drive unit.

NOTE:

Certain models may have a spacer ring (414) between mating surfaces of the suction cover and the volute casing. When there is excessive wear on the surface of the wear ring (408 and 463) it should be replaced.

3.4 ASSEMBLY OF IMPELLER

Before fitting a new impeller or a new impeller bolt, length "L" of impeller bolt should be checked as follows:

By measuring of the impeller and the impeller bolt, it must be secured that:

1. thread reach "L" is $1.25 \times$ thread diameter, e.g. M16:
 $16 \times 1.25 = 20$ mm.
2. end of thread "G1" on impeller bolt is sufficient (re-cut the thread).
3. end of thread "G2" in the shaft is sufficient (shorten impeller bolt, see point 1.).

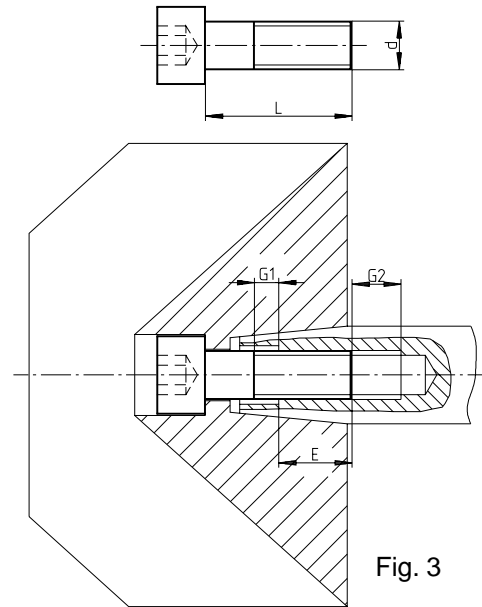

Fig. 3



ATTENTION:

Oil shaft taper slightly with a shred. **NEVER use thick oil, grease or anti-size compound!** Install impeller directly onto shaft. Coat the impeller bolt thread with grease or anti-size compound. Tighten screw with torque according table 3.3.2.

NOTE:

If torque wrench not available, torque can be approximated with an extension pipe and weight.

3.5 FINAL ASSEMBLY

When **ONLY** a new impeller is fitted, a clearance check must be done according 3.2.1.

Assemble spacer ring (411) over the spigot of the drive unit.

Grease O-ring (209) and place into groove on spigot of the drive unit.

Now install drive unit-impeller assembly into volute casing. Install and tighten nuts (419).

See Section 3.2 for correct setting of regulator nuts, or for placement of shims (411) for final adjustment of impeller clearance.